

LAUREN AFENDIS - ALEX STORZ - EMILY WEBSTER



BRILLIANCE

GLASSWARE COLLECTION



PRODUCT NEEDS AND DESIGN SOLUTIONS

Glass has become an increasingly common material for small scale storage containers for prepared foods and ingredients alike. The material is durable, easily cleaned, and has an appealing tactility. What's more, the minimized necessity for plastics and other petrol-based materials increases consumer confidence in the their food's health. As consumers return to this age old food storage material, the future of form and function are drawn into question.

The successes and flaws of storage containers like the Glasslock set shown above influenced the design of our own high-end containers. A slight taper on the set allows for the pieces to slot together while a vast array of sizes and forms allows for any dish or ingredient to find a home. The pieces give off a sleek, but gentle feeling with generously curved edges and a consistent polish.

The major downside to these pieces is their lack of physical or visual texture. The former creates a slippery feeling on the pieces, making them difficult to handle, especially when wet, while the latter gives them an extremely mass-produced feeling, limiting the piece's ability to exist as both a functional and display piece. Glass's unique material properties allow it to exist as more than just a replica of tired plastic storage containers and become a means of enhancing experience in and of itself.

The Brilliance Glassware Collection makes use of glass's ability to slump and polish to create unique pieces that enrich the meal experience. Textures are alternatively slumped or ground into the extended rim of the containers, allowing for an enhanced tactile and visual interaction with each piece. Varying levels of patterning and impression allow the pieces to extend to the range of tastes exhibited by clients.

For high-end restaurants, the luxe containers facilitate a holistic dining experience even with current dining room closures. Their clientele unveil each dish, nestled into its own crystalline container, evoking a sense of surprise and joy at each creation. The containers allow ephemeral luxury of the dining experience to extend beyond the boundaries of the restaurant. For individual clients, these take-out containers provide opportunities to extend splendor into the mundane. The containers both mitigate the waste created by an emerging take-out culture and enhance the dining experience therein.

DESIGN PRECEDENTS AND INSPIRATION



“FOR EVER” “AND EVER”

Katherine Grey

Glass

15 and 16 in. tall

2005

We drew inspiration from the aesthetic and artistic qualities that apply to pieces intended to make serving food containers increasingly more convenient.



“STACKABLE BOTTLES”

Katie Plunkard

Glass

ca. 2015

These bottles demonstrate convenience in the stackable containers and various ways to use the individual components to fit different needs.



“KUBUS”

Wilhelm Wagenfeld

Vereinigte Lausitzer Glaswerke

Glass

ca. 1938

The elegance of this iteration on a module guided our understanding of how simple forms might be combined to create a larger collection.



“ROVER STAINLESS STEEL LUNCHBOX”

Planet Box

Stainless Steel

2020

This example served as inspiration to make our design with several compartments allowing for storage and transportation of multiple foods.

DESIGN PROCESS

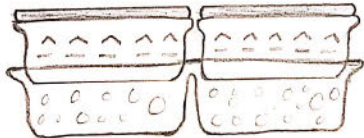
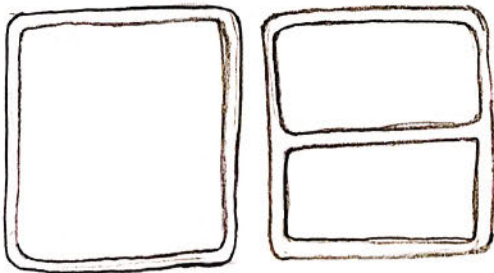
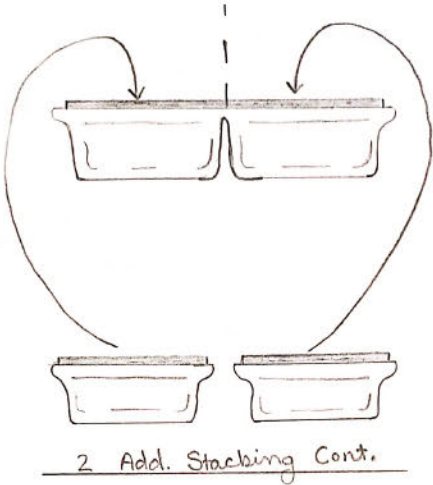
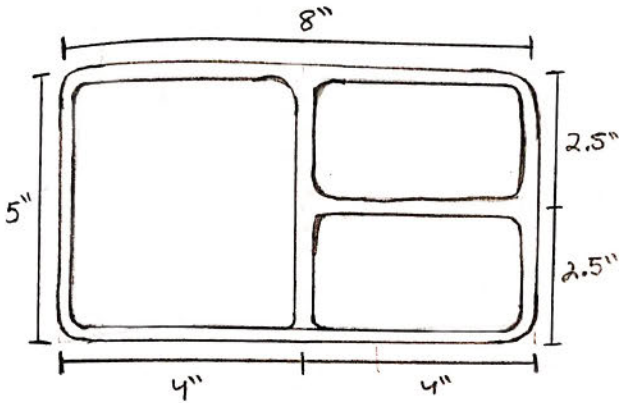

CONTAINER DESIGN

These containers were developed as a series of mold components that could be combined into larger containers or separated for side dish containers. This modulation allows for easy stacking between various containers

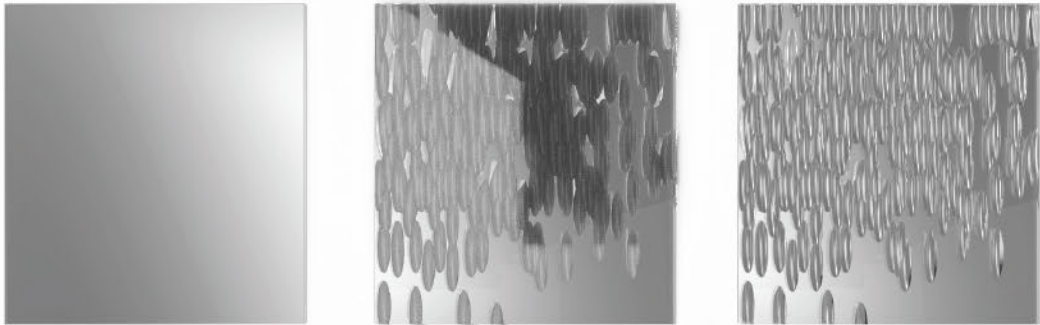

TEXTURING PROCESS

The texturing process takes advantage of the subsequent kiln slumping to create an even finish across the textured surface. Plate glass is textured using a grinding wheel into the desire pattern and then fire polished through the kiln processes.

DESIGN PROCESS

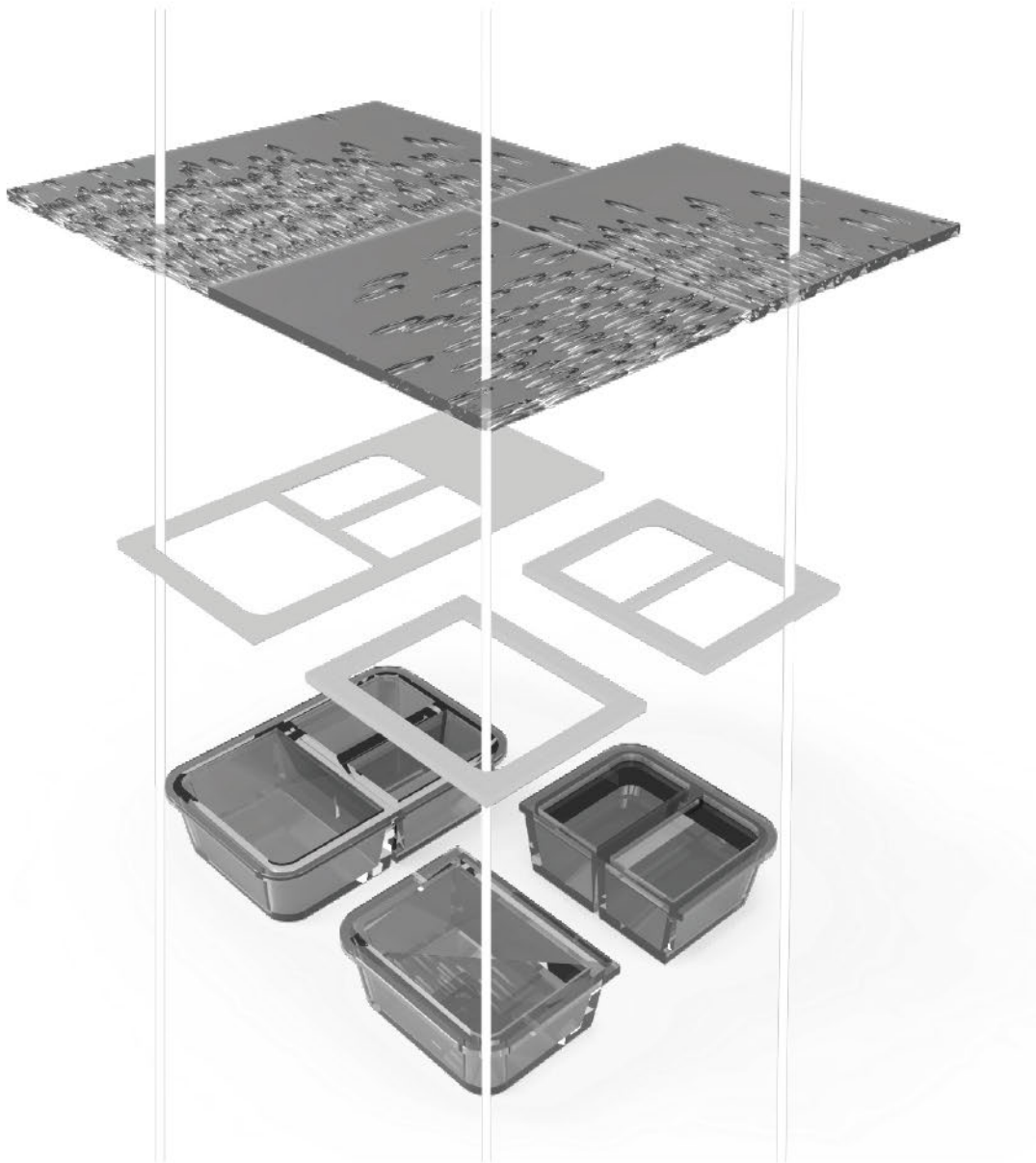

FORMING PROCESS

Textured sheets of glass are placed atop the desired forms inside of a kiln. Through a kiln slumping process, the glass drops into the form's voids, creating the container's compartments.

TEXTURE SAMPLES

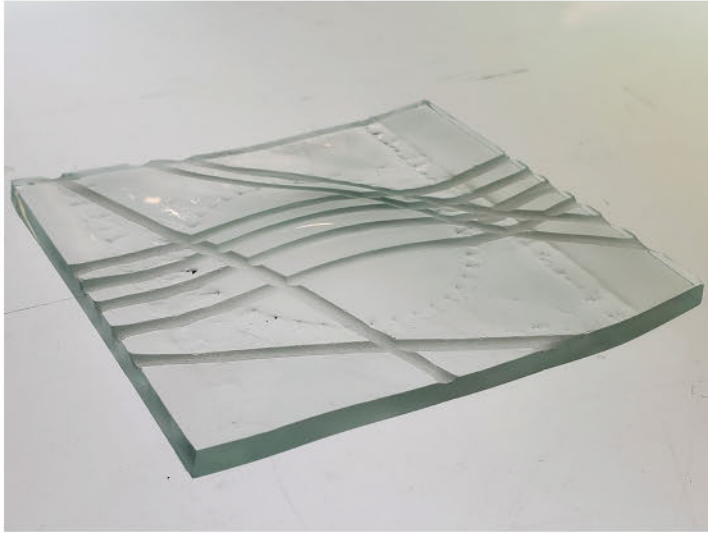

LINE PATTERNING

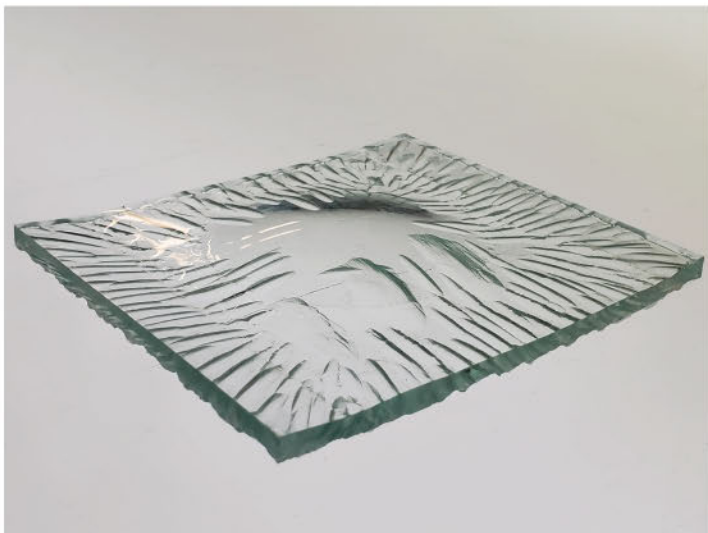

RADIAL GRIPS

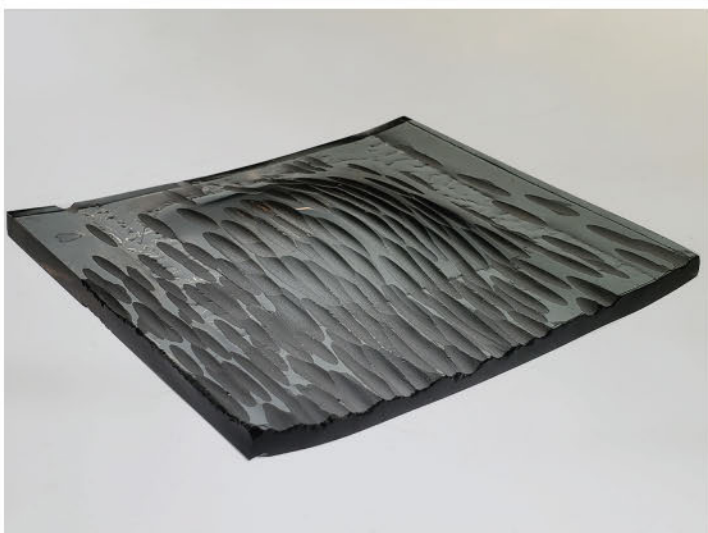

GRADIENT 'HAMMERED' TEXTURE



BENTO WITH ALTERNATIVE PIECES AND LARGE CONTAINER SHOWN ABOVE

LARGE CONTAINER WITH PLATTER STYLE LID SHOW LEFT

Use of a texture mold in the slumping process imparts a secondary texture onto the pieces, giving each one a dimpled texture along the gripping edge that also serves to contrast the smooth slumped interiors.





BENTO IN SERVING ORIENTATION AND LARGE CONTAINER SHOWN ABOVE

BENTO IN CLOSED ORIENTATION SHOWN LEFT



Oversized lids create a moment of reveal as each dish is unveiled. Food is served on the delicately textured glass pieces while the wooden lids serve as supplemental serving trays or tray stabilization as needed.

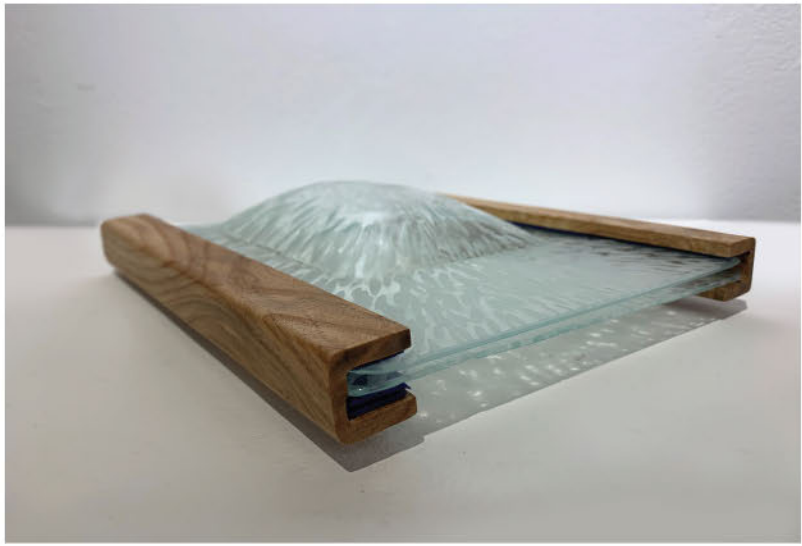

SLIDE LOCK COMPONENTS SHOWN TOP
SLIDE LOCK ASSEMBLY SHOWN BOTTOM

The slide lock design creates a secondary used for the bento bases as they can be incorporated into this sleeker component-based design. The glass elements are able to be pulled apart into individual serving trays, perfect for a shared meal.

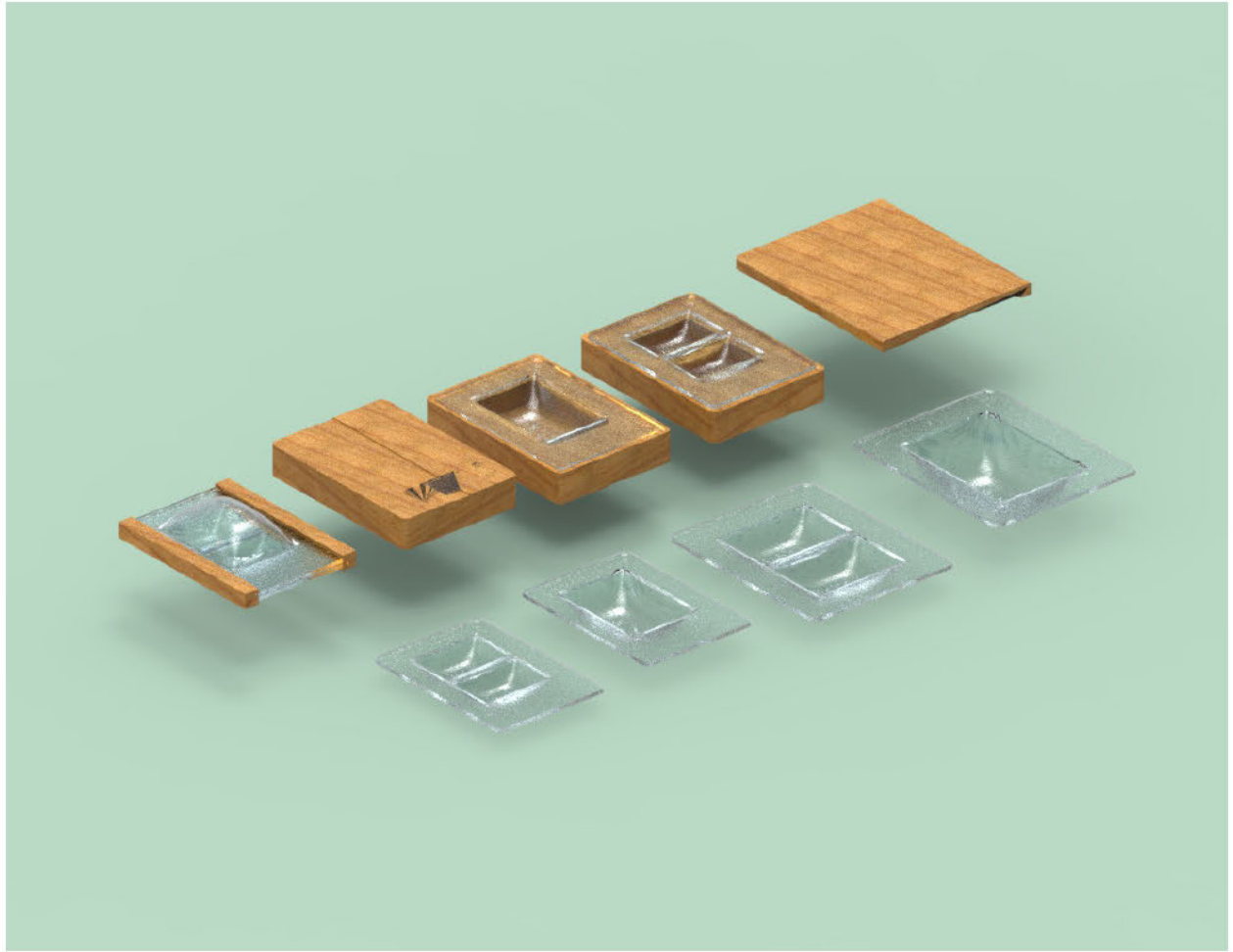

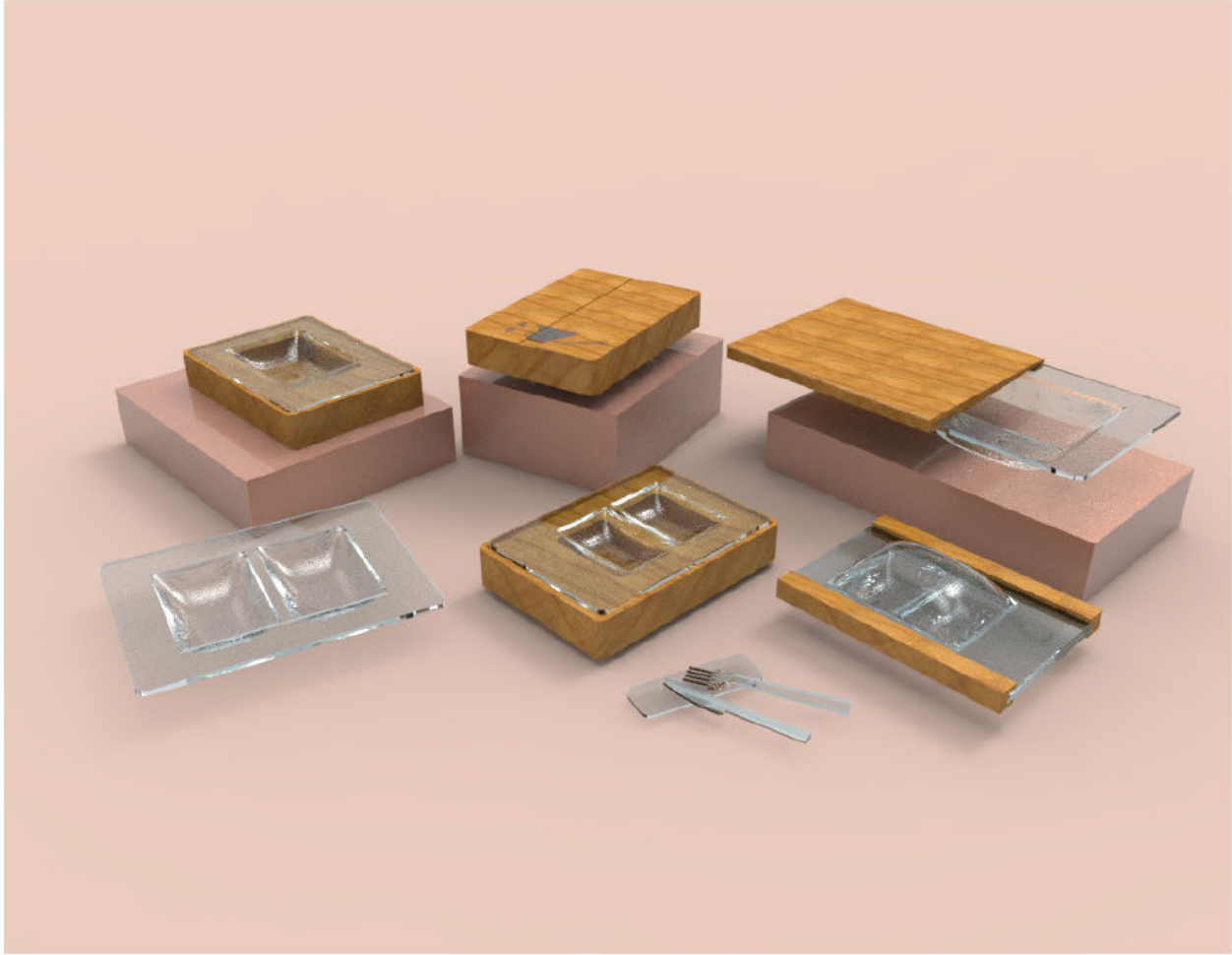

DESIGN DRAWINGS

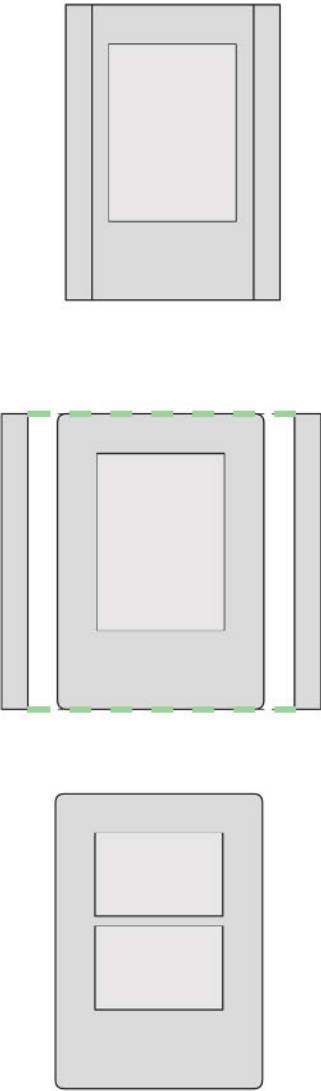

SLIDE LOCK

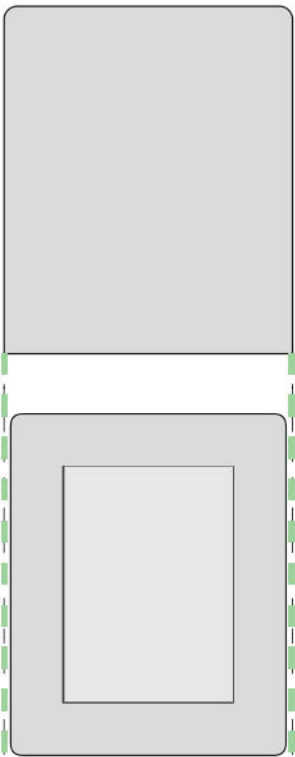

DEEP DISH

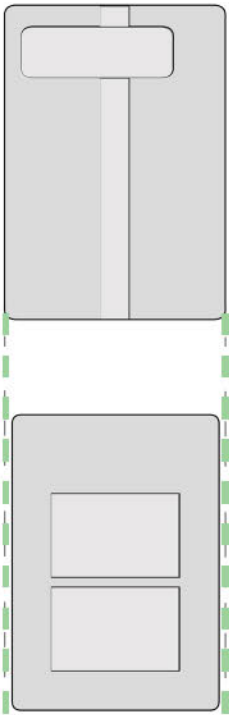

BENTO BOX

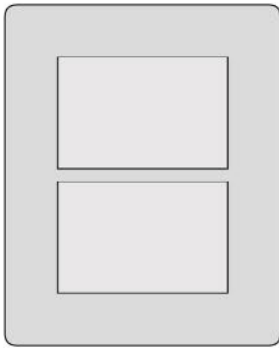

SERVING TRAY

BRILLIANCE BENTO BOX

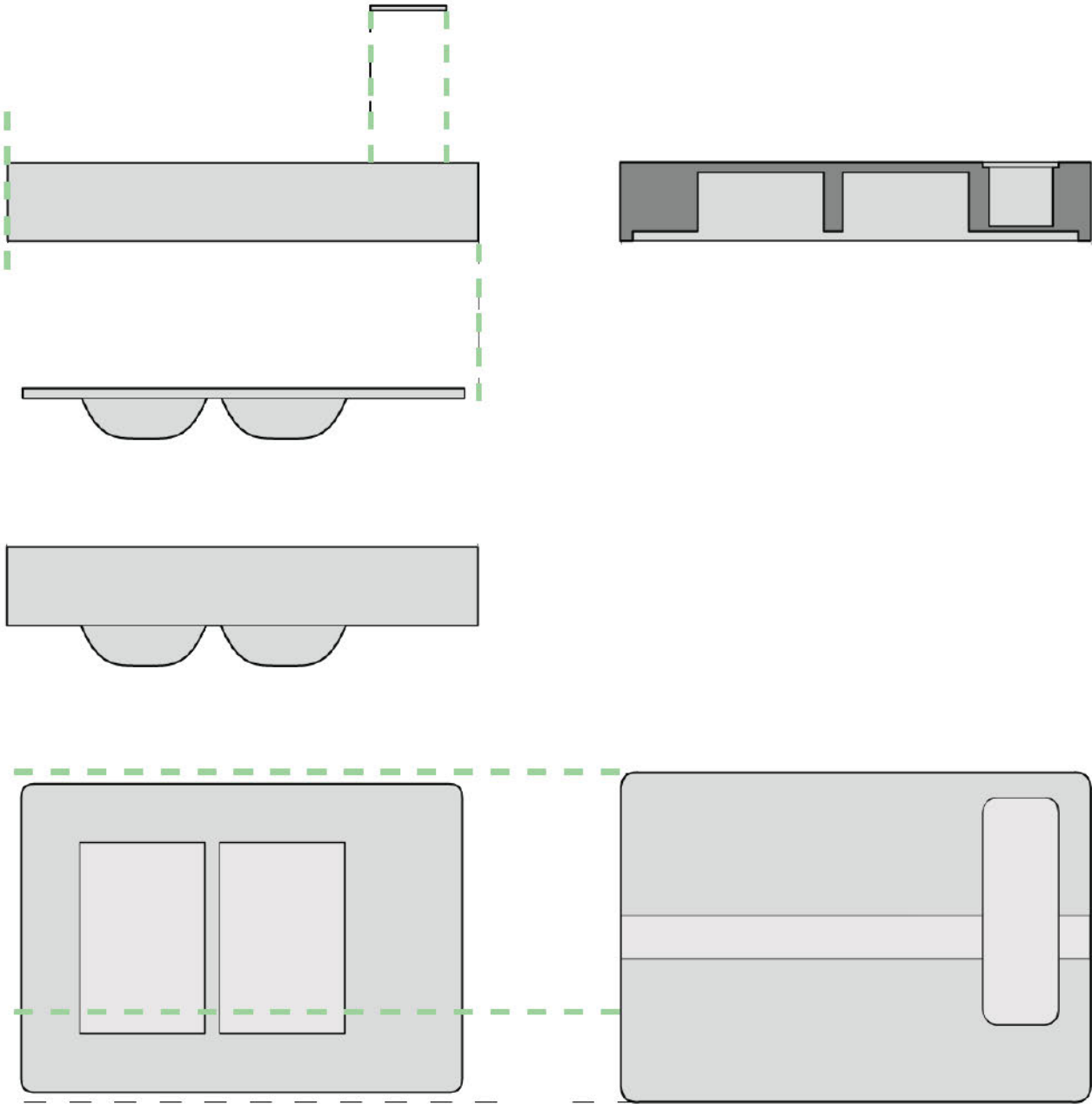

BRILLIANCE SLIDE LOCK

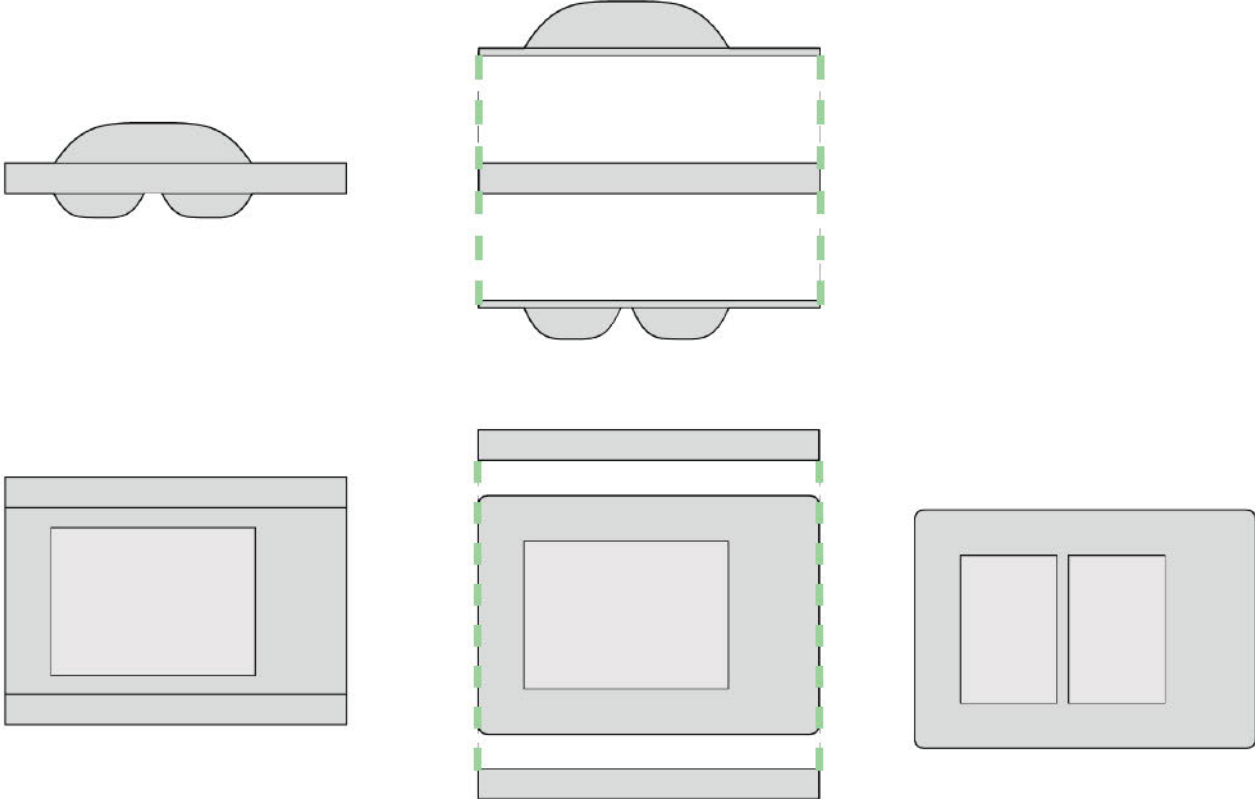

BRILLIANCE DEEP DISH

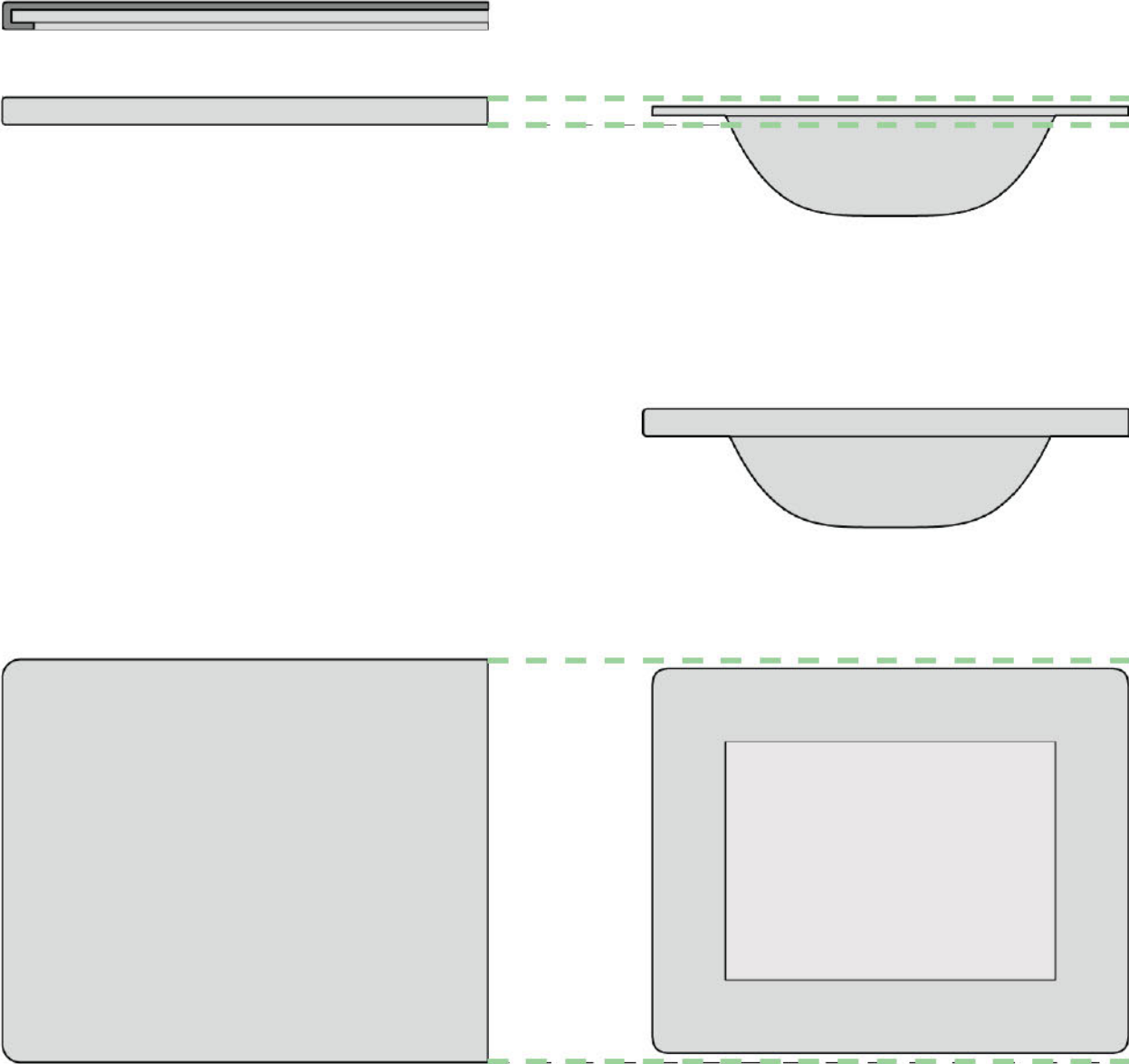



BRILLIANCE

GLASSWARE COLLECTION