

# The *Living* Wall

biophilic presence | sensory impact | interaction opportunity

**SITE:** Children's TherAplay is a clinic located in Carmel, Indiana that is dedicated to serving children with special needs through interaction with therapists via hippotherapy and occupational therapy.

**ABOUT:** The Living Wall will be placed in the sensory or gym area of Children's TherAplay in Carmel, Indiana. With this in mind, the concept of tranquility was a focus for the project. Tranquility is the quality or state of being **FREE** from **AGITATION** of mind or spirit and **FREE** from **DISTURBANCE** or **TURMOIL**. We want to support a peaceful area that represses cognitive hindrances and encourages

progression of the children who will use the space. The Living Wall provides an opportunity for children to interact with nature while in a safe environment. They will be able to touch and water the various plants while viewing the unique colors and qualities

of each. It is our hope that this installation will be a supportive and calming addition to Children's TherAplay for many years to come.

## Process:

1



The first step in the construction of The Living Wall was to create a box that would eventually house the soil and plants. A piece was inserted in the middle to help support the future irrigation system. PVC piping was inserted to provide irrigation via holes drilled into the sides. Plastic sheeting was also added to line the box and make it waterproof.

2



## Final Furniture Piece

3



4





1. Heart Fern

2. Swedish Ivy

3. Neon Pathos



4. Pilea Tiny Tears

5. Spider Plant

6. Wandering Jew

**Plant Care:** Plants chosen are all safe for children, require low light and maintenance, and will continue to grow and flourish when cared for.

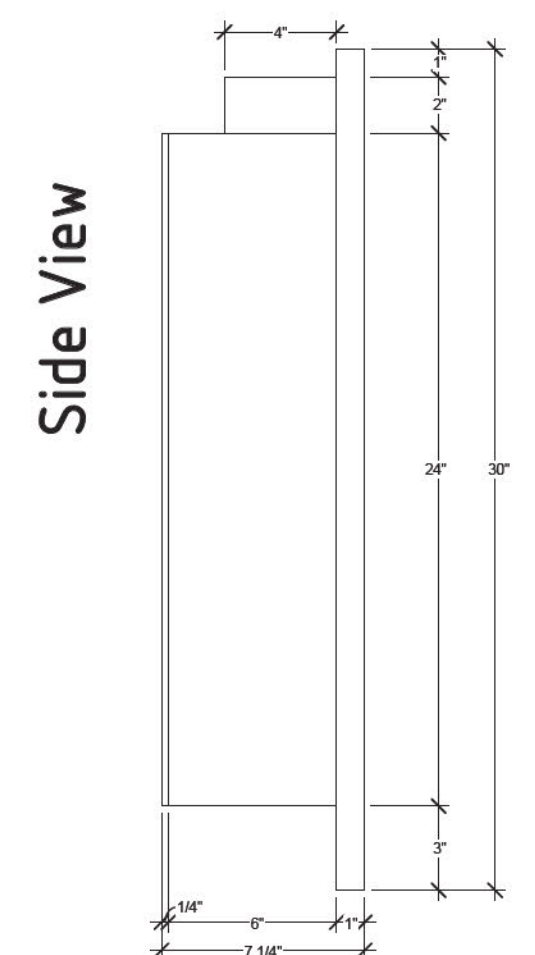
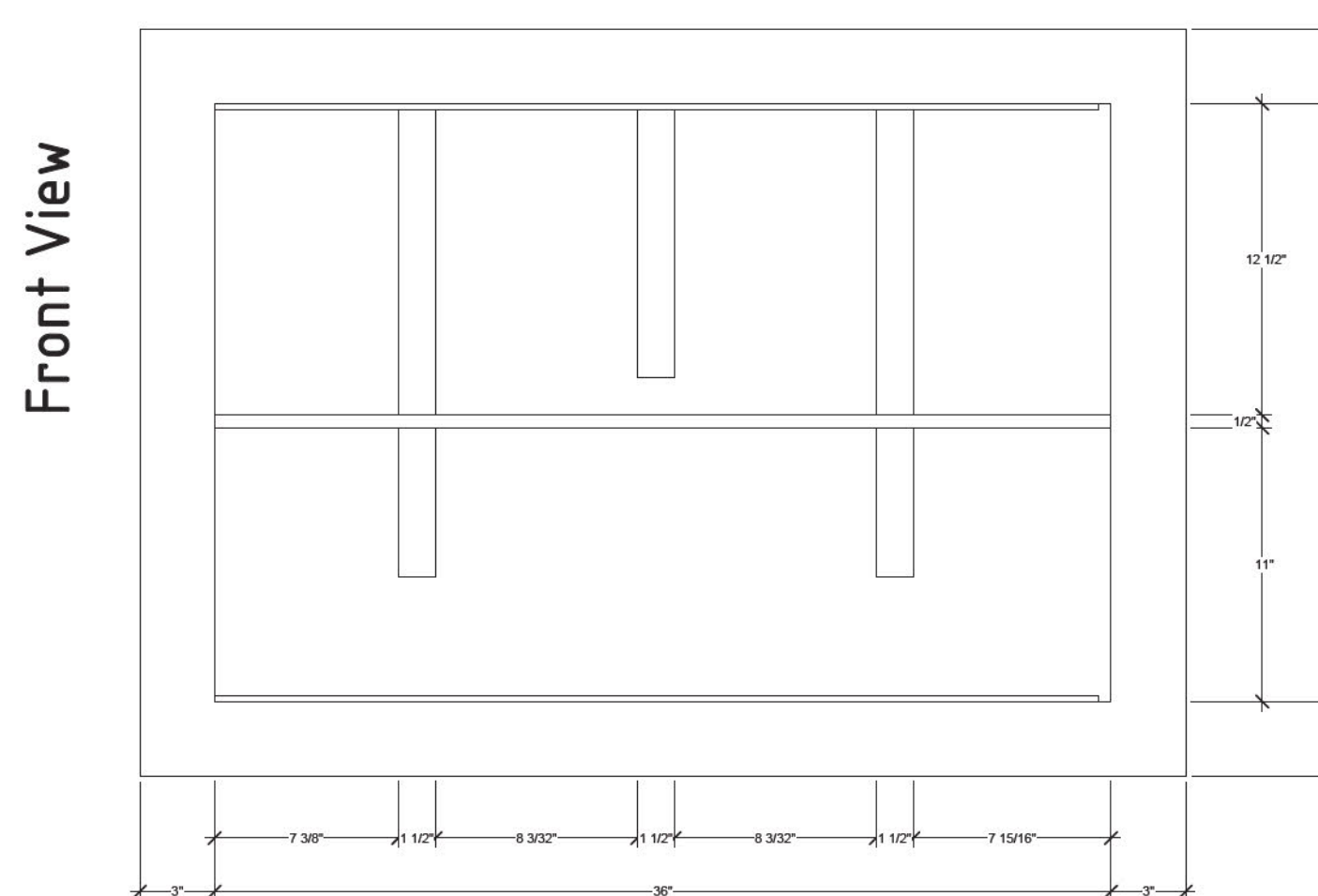
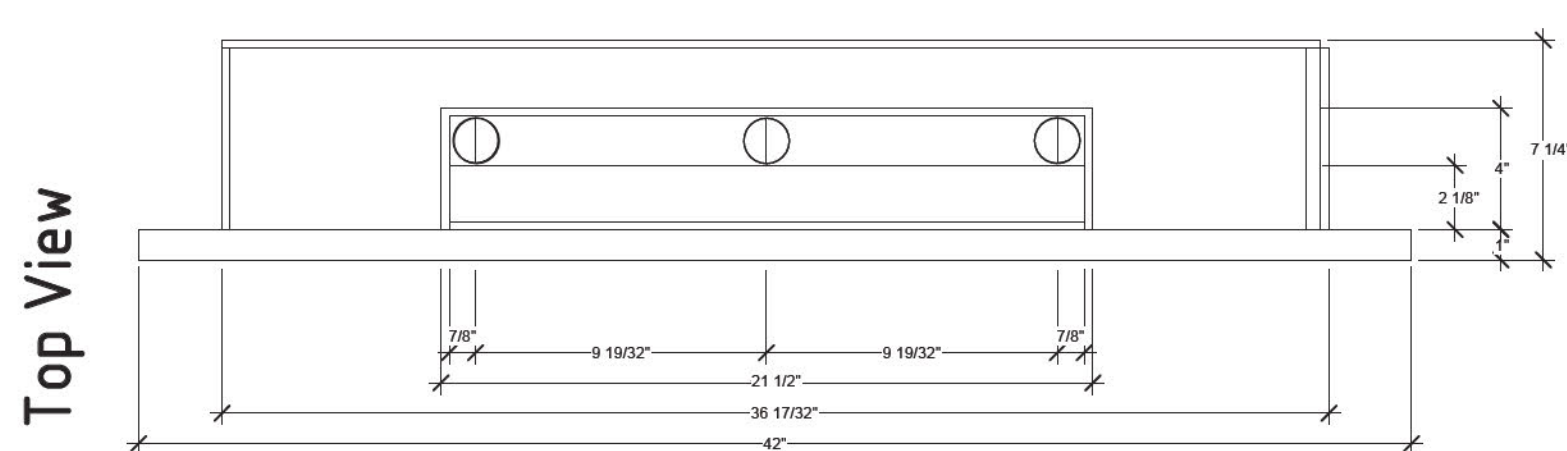
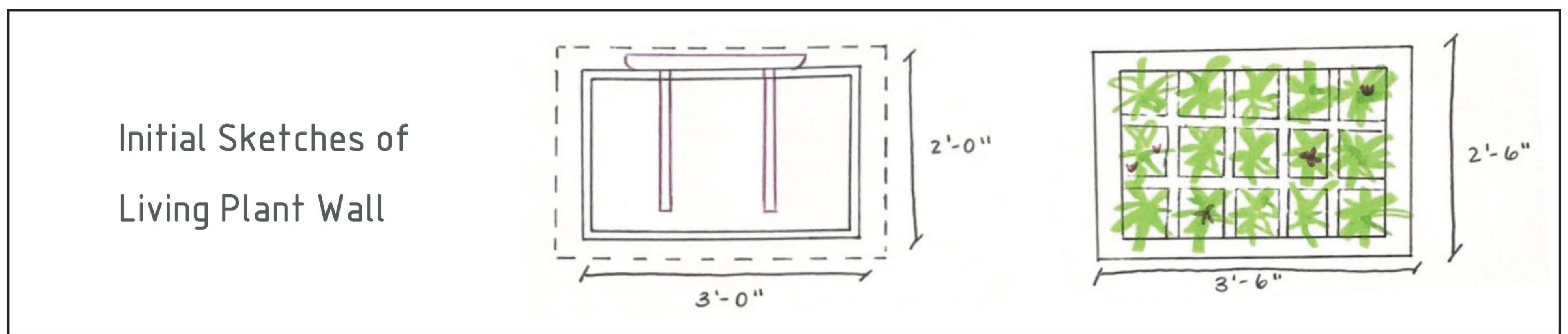

Final Construction Documents of Living Green Wall

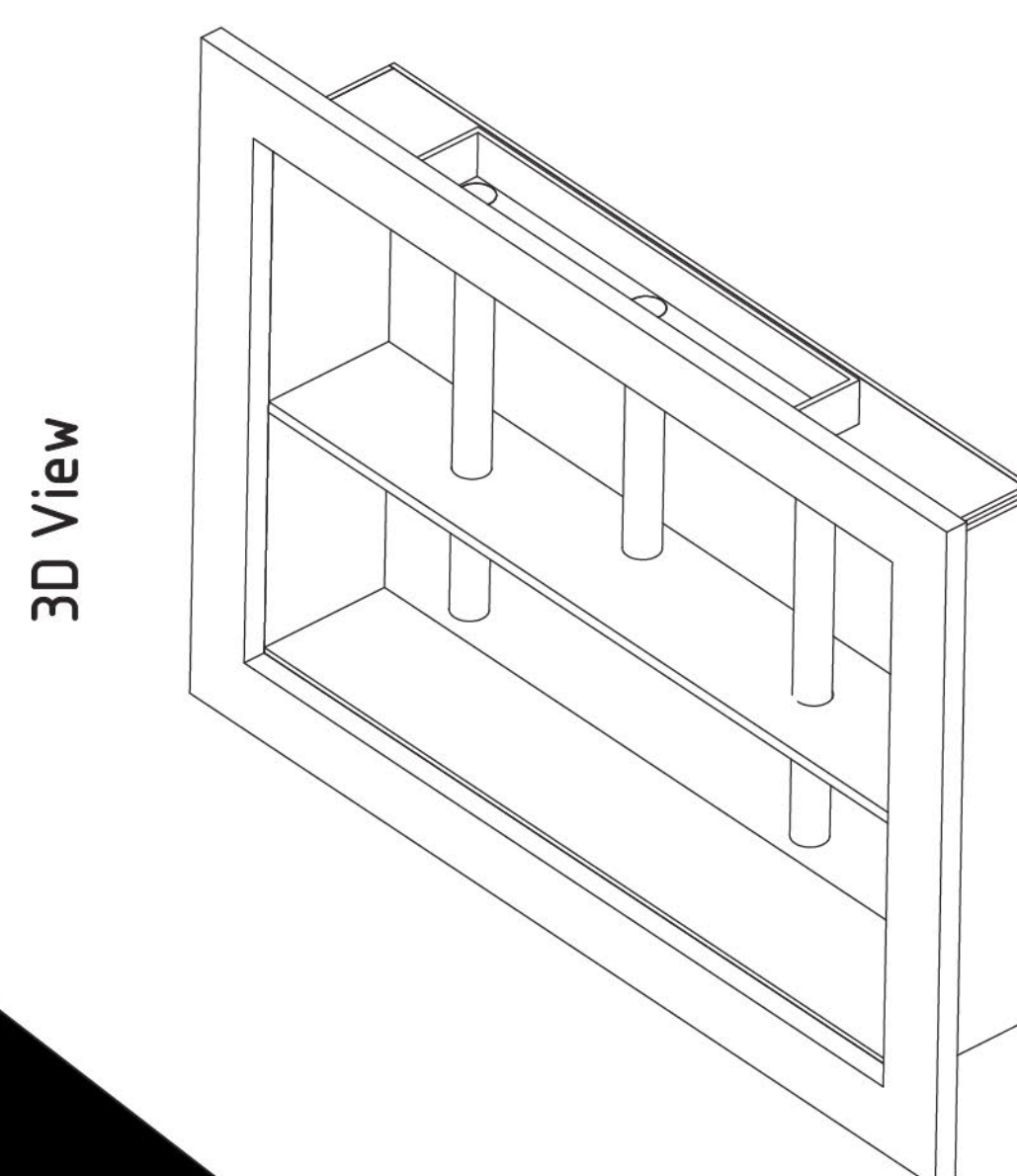

A trough was constructed at the top to complete the irrigation system and soil was inserted into the box. Weed blocker then lined the top to help contain the soil once vertical. A lattice was also added to help support the plants that would then be planted next. To complete The Living Wall, the exterior wood was stained and the frame was added to give it a polished and finished look.